

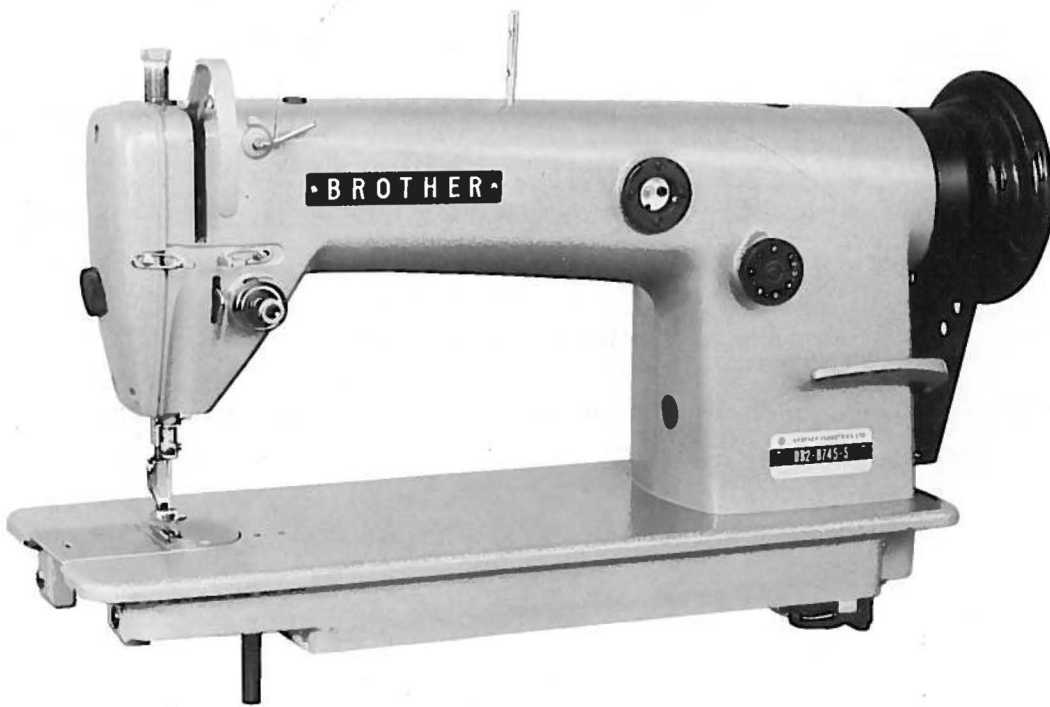

PARTS BOOK
FOR
BROTHER DB2-B745



Single Needle Decorative Stitch Sewing Machine

BROTHER INDUSTRIES, LTD.
NAGOYA, JAPAN

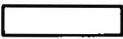
How to use the parts book

1. When the column for the parts number or the parts assembly number is , please refer to the different parts list on the page 8.
2. When the column for the parts number is , the parts cannot be supplied. But when the parts assembly number is shown in the column, please order the parts by the parts assembly number so that the parts can be arranged in the form assembled parts.
3. This book is edited basing on the data as of the September, 1977.
4. The parts in this book may be changed without any advance notice.

CONTENTS

A. Machine Body.....	1
B. Upper Shaft, Needle Bar, Thread Take-up Mechanism	2
C. Feed Mechanism	3
D. Feed, Rotary Hook Mechanism	4
E. Presser Foot, Knee Lifter Mechanism	5
F. Lubrication	6
Z. Accessories	7
DIFFERENT PARTS LIST.....	8
INDEX	8

A. Machine Body

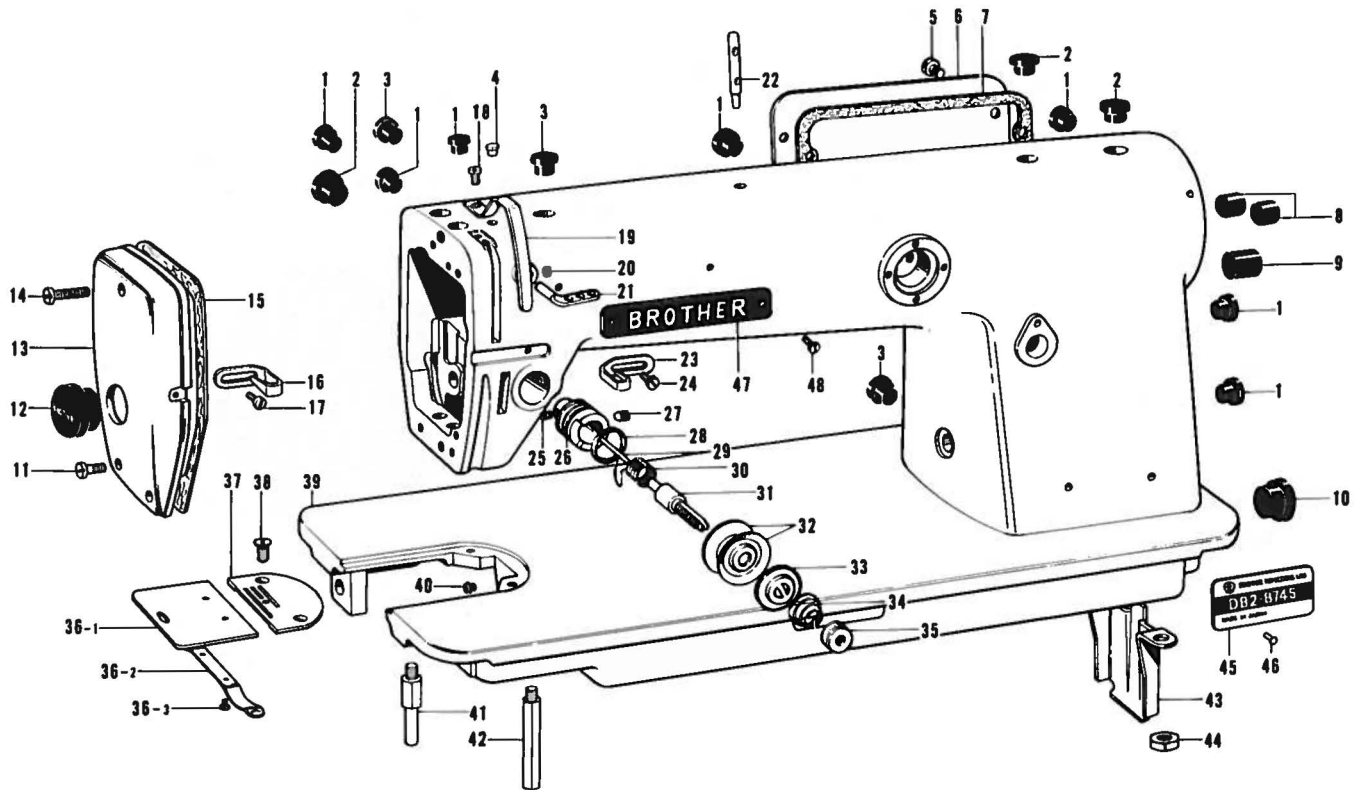

Ref. No.	Name of Parts	Q'ty	Parts No.	Assembly No.	Ref. No.	Name of Parts	Q'ty	Parts No.	Assembly No.
A-1	Vinyl Cap	7	104450-0-01		A-27	Screw	1	103950-0-02	
A-2	Oil Cap	3	104449-0-01		A-28	Packing	1	114294-0-01	
A-3	Oil Cap	3	104821-0-01		A-29	Tension Release Pin	1	100400-0-00	
A-4	Cap for Oil Inlet	1	111865-0-01		A-30	Thread Take-up Spring	1	100399-0-01	
A-5	Screw	4	009670-8-12		A-31	Tension Stud	1	100398-0-01	
A-6	Rear Cover	1	111456-0-01		A-32	Tension Disc	2	145446-0-01	
A-7	Packing	1	111457-0-01		A-33	Presser for Tension Disc	1	100134-0-01	
A-8	Oil Cap	2	104832-0-01		A-34	Tension Spring	1		
A-9	Oil Cap	1	104451-0-01		A-35	Tension Control Nut	1	100136-0-01	
A-10	Oil Cap	1	108520-0-01		A-36-1	Slide Plate	1		A-36 Slide Plate Assembly 180018-0-01
A-11	Screw	2	009671-0-13		A-36-2	Slide Plate Spring	1	114561-0-01	
A-12	Oil Cap	1	112782-0-01		A-36-3	Screw	2	122771-0-01	
A-13	Face Plate	1	147340-0-01		A-37	Needle Plate	1	147322-0-01	
A-14	Screw	1	009671-8-13		A-38	Screw	2	100032-0-03	
A-15	Packing	1	109195-0-01		A-39	Arm-Bed Assembly	1		
A-16	Thread Retainer	1	147339-0-01		A-40	Oil Cap	1	104833-0-01	
A-17	Screw	1	009670-6-14		A-41	Bed leg B	1	104830-0-01	
A-18	Screw	1	009680-7-13		A-42	Bed leg A	1	104829-0-01	
A-19	Thread Take-up Cover	1	147338-0-01		A-43	Pump Cover	1	145454-0-01	
A-20	Screw	1	013680-6-12		A-44	Nut	2	100090-0-04	
A-21	Thread Retainer	1	114931-0-01		A-45	Model Plate	1		
A-22	Spool Pin	1	147557-0-01		A-46	Pin	2		
A-23	Thread Retainer	1	147339-0-01		A-47	Name Plate "BROTHER"	1		
A-24	Screw	1	009670-6-14		A-48	Screw	2		
A-25	Screw	1	100402-0-04						
A-26	Upper Tension Regulator Bracket	1	144741-0-01						

B. Upper Shaft, Needle Bar, Thread Take-up Mechanism

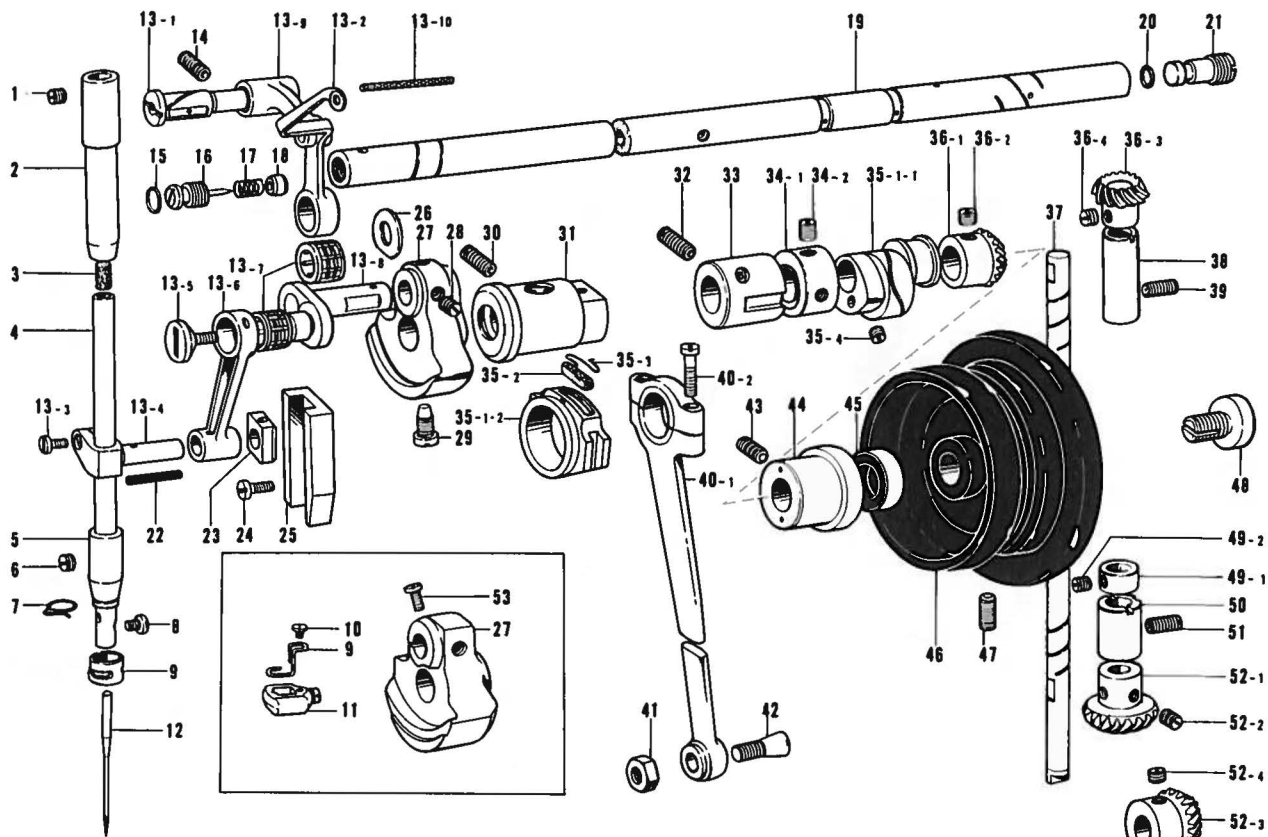

Ref. No.	Name of Parts	Q'ty	Parts No.	Assembly No.	Ref. No.	Name of Parts	Q'ty	Parts No.	Assembly No.
B-1	Screw	1	100260-0-01		B-31	Upper Shaft Bushing Left	1	111459-0-01	
B-2	Needle Bar Bushing Upper	1	111463-0-01		B-32	Screw	1	013761-4-10	
B-3	Needle Bar Cork	1	111863-0-01		B-33	Upper Shaft Bushing Intermediate	1	140726-0-00	
B-4	Needle Bar	1			B-34-1	Collar	1		B-34 Collar 181994-0-01
B-5	Needle Bar Bushing D	1			B-34-2	Screw	2	013760-8-10	
B-6	Screw	1	100260-0-01		B-35-1-1	Feed Cam	1		B-35-1 Feed Cam Assembly 147345-0-01
B-7	Thread Guide Under	1			B-35-1-2	Feed Cam Sleeve	1		
B-8	Screw	1			B-35-2	Felt	1	106442-0-01	B-35 Feed Cam Assembly 181647-0-01
B-9	Needle Bar Thread Guide	1			B-35-3	Felt Wipe	1	106440-0-00	
B-10	Screw	1			B-35-4	Screw	2	013760-8-10	
B-11-1	Needle Clamp	1		B-11 Needle Clamp	B-36-1	Upper Shaft Gear	1		B-36 Upper Shaft Gear Assembly 180022-0-01
B-11-2	Screw	1			B-36-2	Screw	2	013770-7-10	
B-12	Needle DB	1			B-36-3	Vertical Shaft Gear (Upper)	1		
B-13-1	Thread Take-up Supporter Shaft	1			B-36-4	Screw	2	013770-7-10	
B-13-2	Thread Take-up Lever	1			B-37	Vertical Shaft	1	146330-0-01	
B-13-3	Screw	1	140004-0-01	B-13 Take-up Lever Complete 147323-0-01	B-38	Vertical Shaft Upper Bushing	1	142708-0-00	
B-13-4	Needle Bar Clamp	1			B-39	Screw	1	013760-6-10	
B-13-5	Screw	1	145465-0-01		B-40-1	Crank Rod	1		B-40 Crank Rod Assembly 182049-0-01
B-13-6	Needle Bar Crank Rod	1			B-40-2	Set Screw	2	107428-0-01	
B-13-7	Needle Roller Bearing	2			B-41	Nut	1	104689-0-01	
B-13-8	Needle Bar Crank	1			B-42	Taper Screw	1	100310-0-01	
B-13-9	Thread Take-up Lever Supporter	1	147324-0-01		B-43	Screw	1	013760-6-10	
B-13-10	Wick	1	140430-0-01		B-44	Upper Shaft Bushing R	1	146331-0-01	
B-14	Screw	1	013761-4-10		B-45	Oil Seal	1	101487-0-00	
B-15	Packing	1	118770-0-01		B-46	Arm Pulley	1	147327-1-01	
B-16	Oil Adjusting Screw for Upper Shaft	1	140412-0-01		B-47	Screw	2	013761-4-10	
B-17	Spring	1	116799-0-01		B-48	Screw	1	104478-0-01	
B-18	Oil Bushing	1	140357-0-01		B-49-1	Collar	1		B-49 Collar 181995-0-01
B-19	Upper Shaft	1	109137-0-01		B-49-2	Screw	2	101706-0-03	
B-20	O Ring	1	081002-6-70		B-50	Vertical Shaft Bushing (Lower)	1	117054-0-00	
B-21	Oil Screw Right for Upper Shaft	1	104555-0-01		B-51	Screw	1	013761-4-10	
B-22	Wick	1	108809-0-01		B-52-1	Vertical Shaft Gear (Lower)	1		B-52 Lower Shaft Gear Assembly 180023-0-01
B-23	Needle Bar Guide Slide Block	1	102630-0-01		B-52-2	Screw	2	013770-7-10	
B-24	Screw	2	009670-6-12		B-52-3	Lower Shaft Gear	1		
B-25	Needle Bar Guide	1	102631-0-00		B-52-4	Screw	2	013770-7-10	
B-26	Washer	1	110367-0-01		B-53	Screw	1		
B-27	Thread Take-up Crank	1							
B-28	Screw		013770-7-10						
B-29	Screw	1	104464-0-01						
B-30	Screw	1	013761-4-10						

C. Feed Mechanism

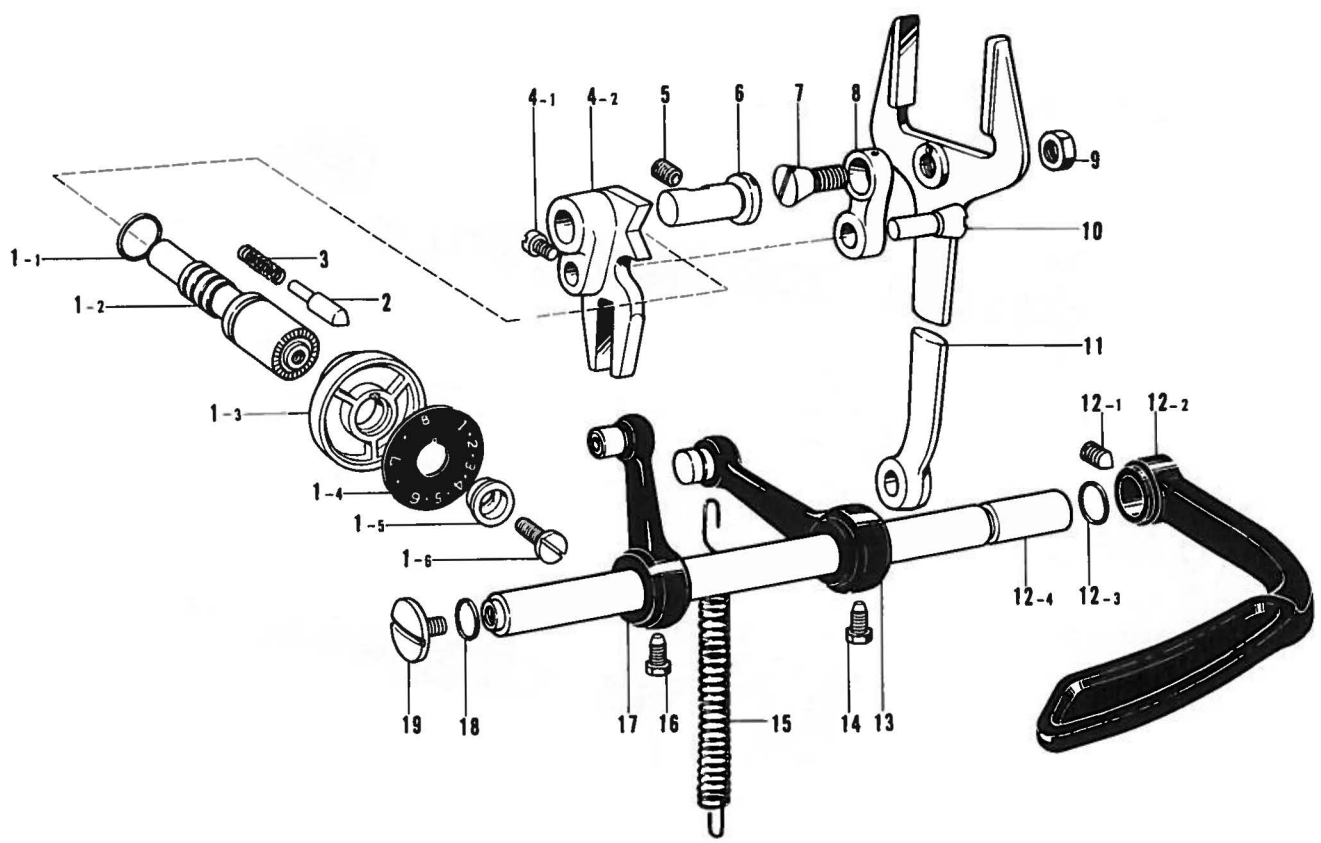

Ref. No.	Name of Parts	Q'ty	Parts No.	Assembly No.	Ref. No.	Name of Parts	Q'ty	Parts No.	Assembly No.
C- 1- 1	Packing	1	108549-0-01	C- 1 Length Control Assembly 181709-0-01	C-10	Taper Hinge	1	100312-0-01	
C- 1- 2	Length Control Screw	1	109151-1-01		C-11	Feed Forked Connector	1	109147-0-01	
C- 1- 3	Length Control	1	142483-0-01		C-12- 1	Set Screw	1	015771-0-12	C-12 Reverse Lever Assembly 181671-0-01
C- 1- 4	Washer	1	142746-0-02		C-12- 2	Reverse Lever	1	118752-0-01	
C- 1- 5	Length Control Plate	1	147343-0-01		C-12- 3	Packing	1	104564-0-01	
C- 1- 6	Screw	1	142747-0-02		C-12- 4	Feed Regulator Lever Shaft	1	108541-0-01	
C- 2	Notch for Length Control	1	100327-0-01	C-13	Feed Regulator Lever B with Hook	1	108544-0-03		
C- 3	Notch Spring	1	100328-0-01						
C- 4- 1	Screw	1	102627-0-01	C- 4 Feed Regulator 181127-0-01	C-14	Bolt	1	142403-0-01	
C- 4- 2	Feed Regulation	1			C-15	Feed Regulator Tension Spring	1	109150-0-01	
C- 5	Screw	1	013781-0-12		C-16	Bolt	1	108749-0-01	
C- 6	Stud	1	111491-0-01		C-17	Feed Regulator Lever Assembly	1	116953-0-01	
C- 7	Taper Screw	1	100310-0-01		C-18	Packing	1	104564-0-01	
C- 8	Feed Link	1	104897-0-01		C-19	Screw	1	100511-0-03	
C- 9	Nut	1	104689-0-01						

D. Feed, Rotary Hook Mechanism

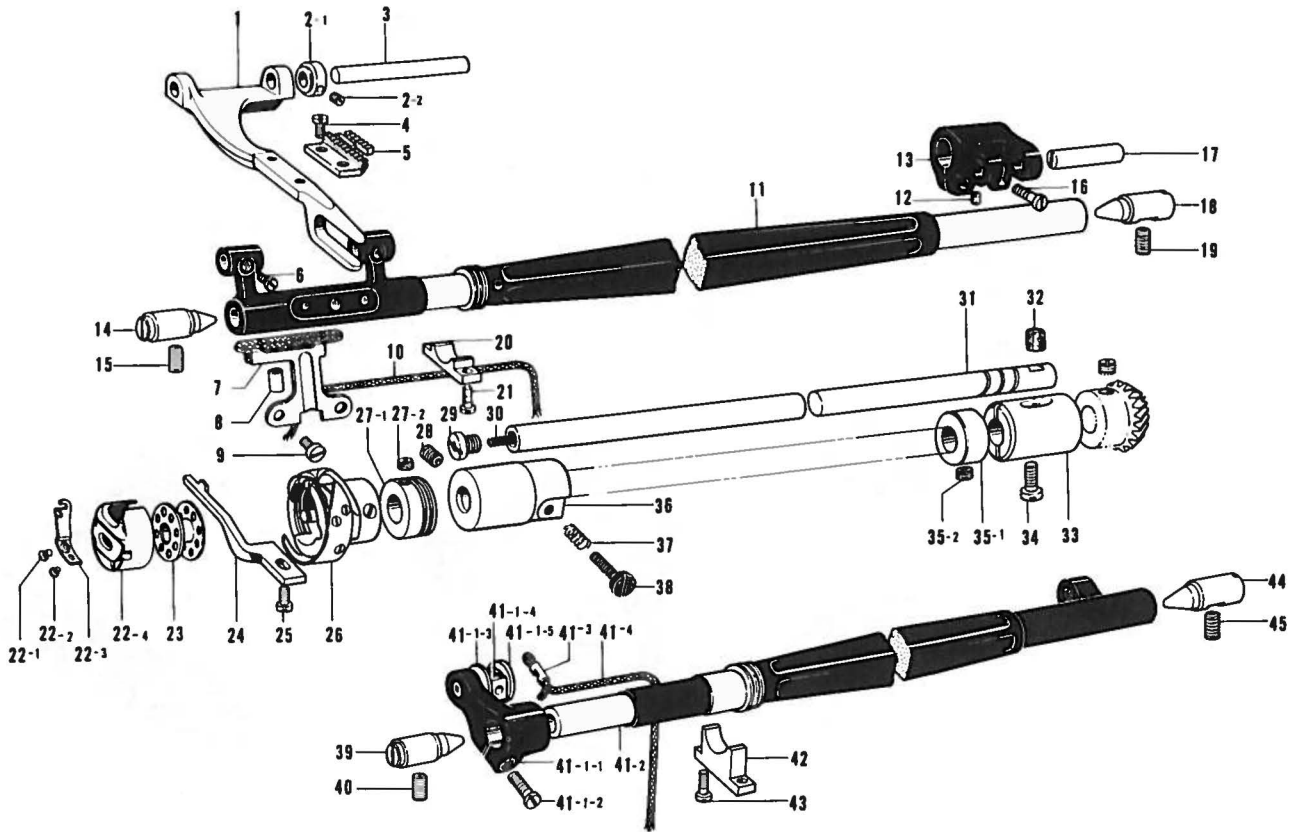

Ref. No.	Name of Parts	Q'ty	Parts No.	Assembly No.	Ref. No.	Name of Parts	Q'ty	Parts No.	Assembly No.
D- 1	Feed Bar	1	147334-0-01		D-26	Rotary Hook Assembly	1		
D- 2-1	Collar	1		D-2 Collar 182048-0-01	D-27-1	Oil Rejector	1		D-27 Oil Rejector 144943-0-01
D- 2-2	Screw	2	144458-0-01		D-27-2	Screw	2	013689-4-12	
D- 3	Feed Bar Shaft	1	109156-0-01		D-28	Screw	1	013680-8-12	
D- 4	Screw	2	100080-0-03		D-29	Screw	1	109173-0-01	
D- 5	Feed Dog	1	147335-0-01		D-39	Oil Felt	1	106436-0-01	
D- 6	Screw	2	104908-0-01		D-31	Lower Shaft	1	147336-0-01	
D- 7	Vinyl Tube	1	104566-0-01		D-32	Felt	1	107155-0-01	
D- 8	Wick Supporter	1	109171-0-01		D-33	Lower Shaft Bushing Right	1	104520-1-00	
D- 9	Screw	2	009670-5-12		D-34	Screw	1	013680-8-12	
D-10	Wick	1	108801-0-01		D-35-1	Collar	1		D-35 Collar 181995-0-01
D-11	Feed Rock Shaft	1	147333-0-01		D-35-2	Screw	2	101706-0-03	
D-12	Screw	1	013689-4-12		D-36	Lower Shaft Bushing Left	1	118761-1-00	
D-13	Feed Rock Shaft Arm	1	144564-0-01		D-37	Spring	1	116794-0-01	
D-14	Taper Center Left	1	104847-0-01		D-38	Screw	1	145534-0-01	
D-15	Screw	1	013770-7-10		D-39	Taper Center Left	1	104847-0-01	
D-16	Screw	2	009681-2-12		D-40	Screw	1	013770-7-10	
D-17	Feed Rock Shaft Arm Pin	1	109153-0-01		D-41-1-1	Feed Lifting Arm	1		D-41-1 Feed Lifting Arm Assembly 181941-0-01
D-18	Taper Center Right	1	104848-0-01		D-41-1-2	Screw	1	009681-6-12	
D-19	Screw	1	013770-7-10		D-41-1-3	Washer	1		
D-20	Oil Stopper	1	118558-0-01		D-41-1-4	Slide Block	1		
D-21	Screw	2	009670-8-12		D-41-1-5	Slide Block Stud	1		
D-22-1	Spring Set Screw	1	181937-0-01		D-41-2	Feed Lifting Rock Shaft	1	108556-0-03	D-41 Feed Lifting Rock Shaft 181718-0-01
D-22-2	Spring Adjusting Screw	1	181938-0-01		D-41-3	Wick Supporter	1	104567-0-01	
D-22-3	Lower Thread Adjusting Spring	1	181936-0-01	D-22 Bobbin Case Assembly 147790-0-01	D-41-4	Wick	1	108802-0-01	
D-22-4	Bobbin Case	1			D-42	Oil Stopper	1	118559-0-01	
D-23	Bobbin	1	117061-0-01		D-43	Screw	2	009670-8-12	
D-24	Bobbin Case Holder Position Bracket	1	147337-0-01		D-44	Taper Center Right	1	104848-0-01	
D-25	Screw	1	009681-0-12		D-45	Screw	1	013770-7-10	

E. Presser Foot, Knee Lifter Mechanism

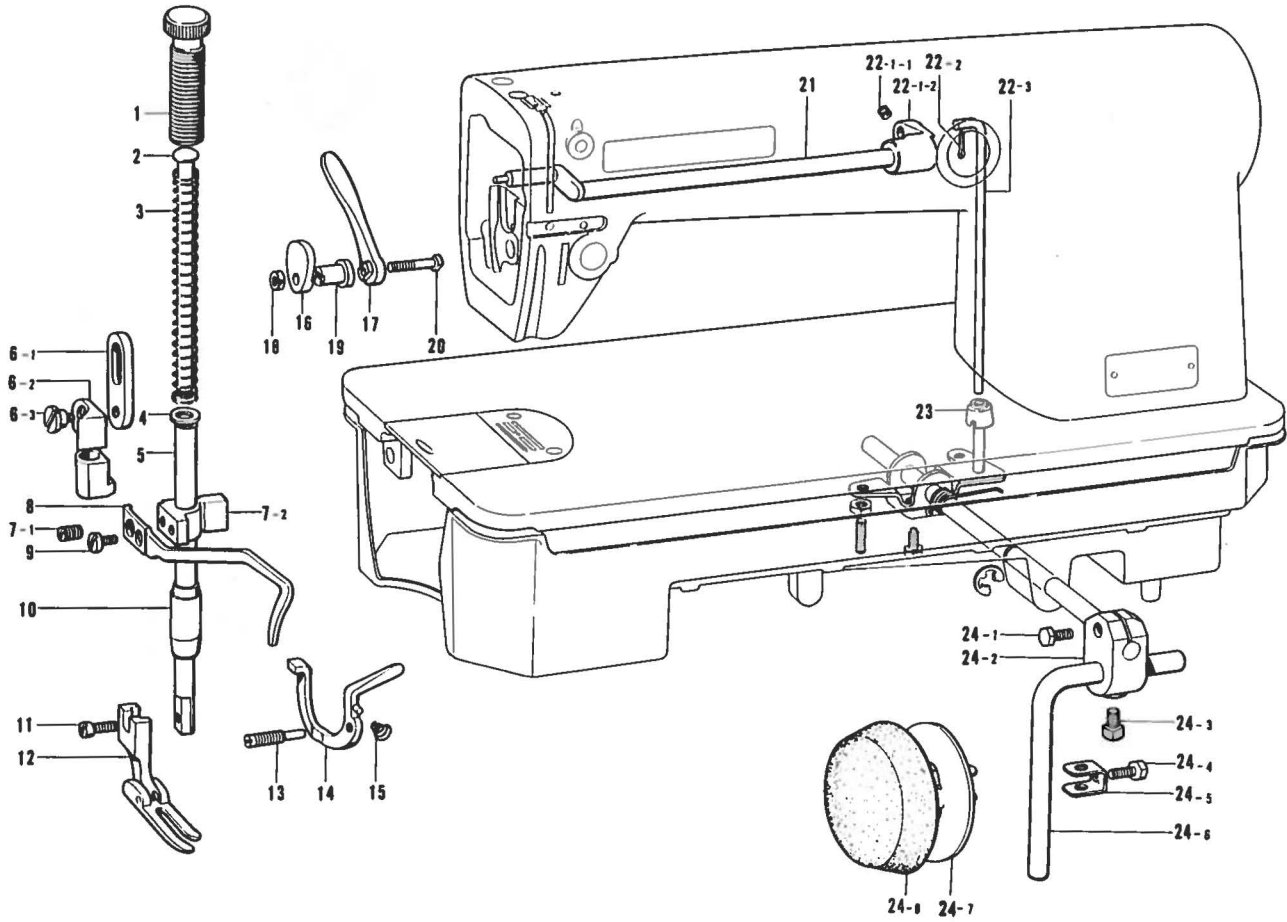

Ref. No.	Name of Parts	Q'ty	Parts No.	Assembly No.	Ref. No.	Name of Parts	Q'ty	Parts No.	Assembly No.
E-1	Screw	1	141207-0-01		E-17	Presser Bar Lifter Lever	1	142016-0-01	
E-2	Presser Spring Bar	1	141208-0-01		E-18	Nut	1	021680-2-02	
E-3	Presser Spring	1	141209-0-01		E-19	Presser Bar Lifter Shaft	1	142017-0-01	
E-4	Presser Spring Washer	1	140407-0-01		E-20	Bolt	1	142018-0-01	
E-5	Presser Bar	1	111466-0-01		E-21	Knee Lifter Upper Crank Shaft	1	109145-0-01	
E-6-1	Presser Bar Lifting Connector	1	109144-0-01	E-6 Presser Bar Lifter Assembly 181719-0-01	E-22-1-1	Screw	1	013770-7-10	E-22-1 Knee Lifter Crank Upper Assembly 142756-0-01
E-6-2	Presser Bar Lifter Bracket	1	147999-0-01		E-22-1-2	Knee Lifter Crank Upper	1		
E-6-3	Screw	1	100294-0-01		E-22-2	Pin	1	045161-0-00	E-22 Knee Lifter Crank Upper Assembly 142756-0-01
E-7-1	Screw	1	013760-8-10	E-7 Presser Bar Guide Bracket 180102-0-01	E-22-3	Knee Lifter Connecting Rod	1	141168-0-01	
E-7-2	Presser Bar Bracket	1			E-23	Knee Lifter Complying Bar	1	145573-0-00	
E-8	Presser Bar Bracket Thread Guide	1	111469-0-01		E-24-1	Bolt	1	017762-0-13	
E-9	Screw	1	009680-7-13		E-24-2	Knee Lifter Joint	1		
E-10	Presser Bar Bushing	1	110340-0-01		E-24-3	Bolt	1	100463-0-01	
E-11	Screw	1	001670-8-14		E-24-4	Bolt	1	110087-0-01	E-24 Knee Lifter Assembly 181427-0-01
E-12	Presser Foot	1	147328-0-01		E-24-5	Knee Lifter Plate Stopper	1		
E-13	Hinge Screw	1	109163-0-01		E-24-6	Knee Lifter Bar	1		
E-14	Tension Release Lever	1	111470-0-00		E-24-7	Knee Lifter Plate	1		
E-15	Spring	1	100405-0-01		E-24-8	Knee Lifter Cover	1	140503-0-01	
E-16	Presser Bar Lifter Cam	1	142015-0-01						

F. Lubrication

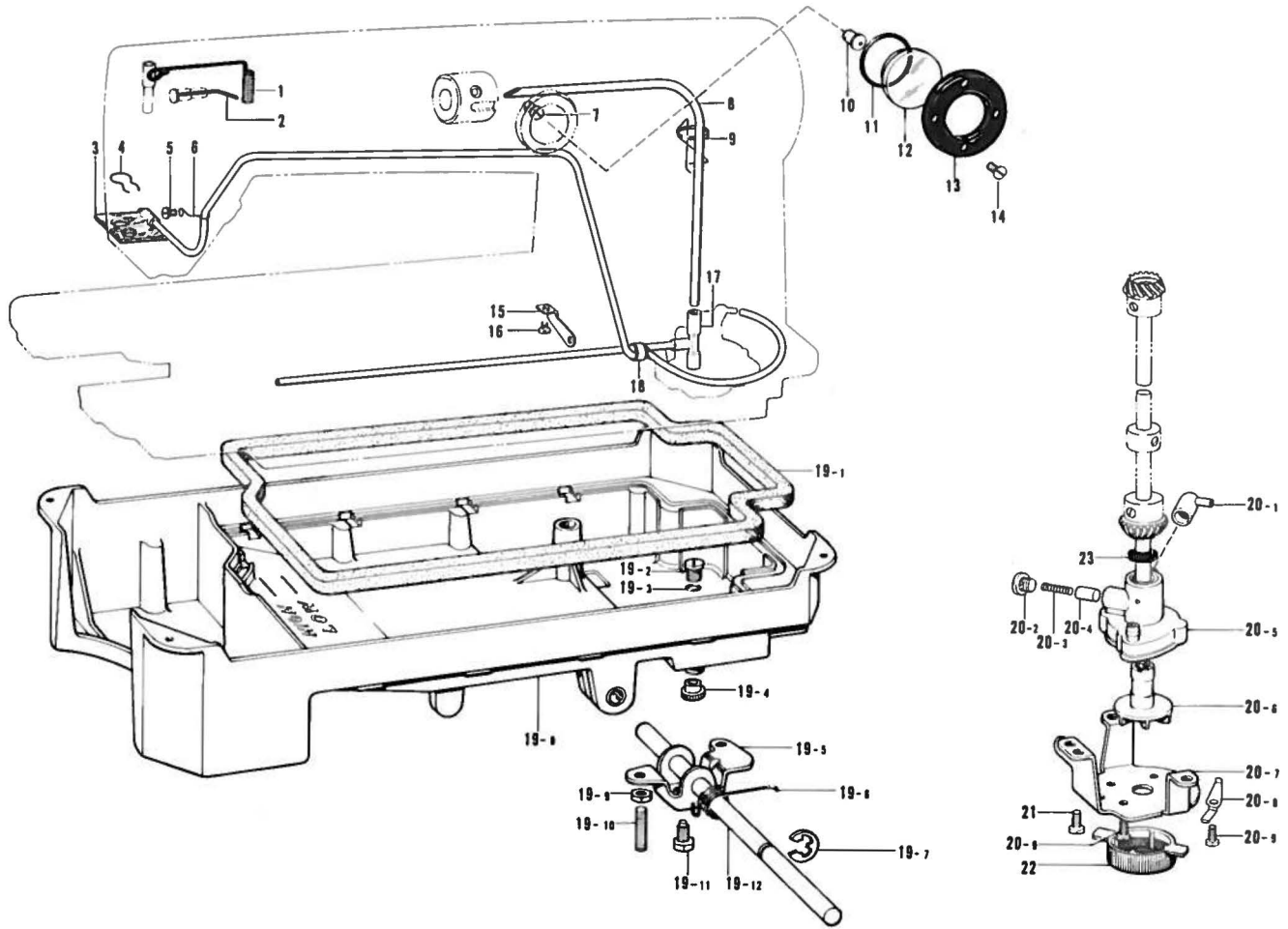

Ref. No.	Name of Parts	Q'ty	Parts No.	Assembly No.	Ref. No.	Name of Parts	Q'ty	Parts No.	Assembly No.	
F- 1	Wick	1	108804-0-01		F-19- 4	Oil Cap	1	140480-0-01	F-19 Oil Pan Assembly 181420-2-01	
F- 2	Wick	1	109405-0-01		F-19- 5	Knee Lifter	1	146037-0-01		
F- 3	Oil Tube Assembly	1	145792-0-01		F-19- 6	Spring	1	146038-0-01		
F- 4	Felt Support	1	145737-0-01		F-19- 7	Stop Ring	1	146293-0-01		
F- 5	Set Screw	1	009670-5-12		F-19- 8	Oil Pan	1	149580-0-01		
F- 6	Tube Holder	1	148806-0-01		F-19- 9	Nut	2	100022-0-04		
F- 7	Screw	1	145992-0-01		F-19-10	Screw	2	104885-0-01		
F- 8	Upper Oil Tube	1	146329-0-00		F-19-11	Bolt	1	146367-0-01		
F- 9	Tube Guard	1	146326-0-01		F-19-12	Knee Lifter Shaft	1	146036-1-01		
F-10	Oil Hole Bolt for Oil Gauge	1	143196-0-01		F-20- 1	Joint	1	144878-0-01		F-20 Pump Assembly 181476-1-01
F-11	O Ring	1	081014-6-70		F-20- 2	Oil Draining Screw	1	112467-0-02		
F-12	Oil Gauge Window	1	104547-0-01		F-20- 3	Spring	1	144876-0-01		
F-13	Oil Gauge Flange	1	104546-0-01		F-20- 4	Plunger	1	144875-0-01		
F-14	Screw	4	102538-0-02		F-20- 5	Pump Body	1	148848-0-01		
F-15	Tube Holder	1	145542-0-01		F-20- 6	Propeller	1	148849-0-01		
F-16	Screw	1	009680-6-12		F-20- 7	Pump	1	144869-0-01		
F-17	Oil Tube	1	145540-0-01		F-20- 8	Spring	2	144874-0-01		
F-18	Tube	1	146253-0-00		F-20- 9	Screw	4	009670-8-12		
F-19- 1	Packing	1	146040-0-01	F-19 Oil Pan Assembly 181420-2-01	F-21	Screw	3	009680-7-13		
F-19- 2	Screw	1	140518-0-01		F-22	Pump Filter	1	144872-0-01		
F-19- 3	O Ring	1	081007-0-70		F-23	Oil Stopper	1	146196-0-01		

Z. Accessories

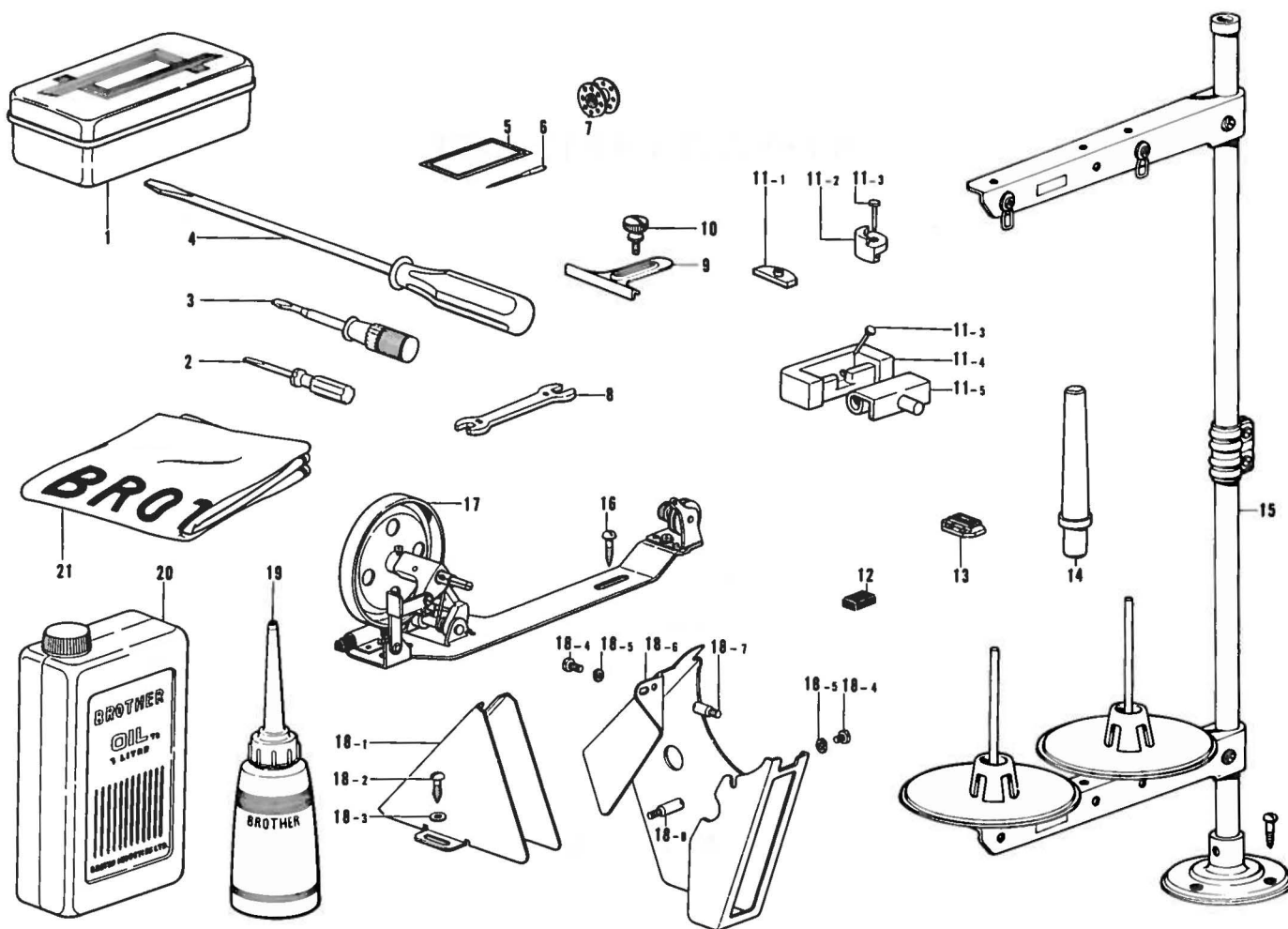

Ref. No.	Name of Parts	Q'ty	Parts No.	Assembly No.	Ref. No.	Name of Parts	Q'ty	Parts No.	Assembly No.
Z- 1	Accessory Box Assembly		110436-0-01		Z-14	Head Rest		100477-0-01	
Z- 2	Screw Driver		142443-0-01		Z-15	Cotton Stand Assembly			
Z- 3	Screw Driver		118837-0-01		Z-16	Screw		100666-0-02	
Z- 4	Screw Driver		101572-1-01		Z-17	Bobbin Winder Assembly		117963-0-01	
Z- 5	Bag				Z-18- 1	Belt Cover D			
Z- 6	Needle DB				Z-18- 2	Screw		100666-0-02	
Z- 7	Bobbin		117061-0-01		Z-18- 3	Washer		025750-1-32	
Z- 8	Spanner 8×9		100887-0-01		Z-18- 4	Screw		009680-8-12	
Z- 9	Ruler		100471-0-01		Z-18- 5	Spring Washer		028680-2-42	
Z-10	Thumb Screw		106120-0-01		Z-18- 6	Belt Cover UE			
Z-11- 1	Oil Pan Cushion		146004-0-01		Z-18- 7	Stud (B)		147856-0-01	
Z-11- 2	Head Cushion		146003-1-01		Z-18- 8	Stud (A)		147855-0-01	
Z-11- 3	Nail		109714-0-00	Z-11 Rubber Hinge Assembly 181294-0-01	Z-18- 9	Cushion		146289-0-01	Z-18 Carton for Belt Cover
Z-11- 4	Blower		143910-0-01		Z-19	Oiler		114483-0-01	
Z-11- 5	Hinge		143882-0-01		Z-20	Oil Tank		145277-1-03	
Z-12	Magnet		112525-0-00		Z-21	Head Cover		144222-0-01	
Z-13	Feed Dog		147493-0-01						

* The details of included accessories are subject to change.

* Änderungen in der Aufstellung der mitgelieferten Zubehöre sind vorbehalten.

* Les détails des accessoires inclus sont sujets à des changements.

* Los detalles de los accesorios incluidos pueden variar.

DIFFERENT PARTS LIST

Ref. No.	Specification	-7				-5					
		80702	80703	80704	80708	80502	80503	80504	80505	80506	80507
A-34	Tension Spring	145153-0-01				104525-0-01					
B-4	Needle Bar	116017-0-01				147518-0-01					
B-5	Needle Bar Bushing D	117117-0-01				147326-0-01					
B-7	Thread Guide Under					100573-0-01					
B-8	Screw					140553-0-01					
B-9	Needle Bar Thread Guide	118382-0-01				112775-0-01					
B-10	Screw	140530-0-01									
B-11	Needle Clamp	180166-0-01									
B-12	Needle	100265-0-39				147779-0-22					
B-27	Thread Take-up Crank	148296-0-00				117913-0-00					
B-53	Screw	009711-2-12									
D-26	Rotary Hook Assembly	150487-0-01				147789-0-01					
Z-6	Needle	100265-0-39				147779-0-22					
Z-15	Cotton Stand Assembly	150150-0-01				150150-0-01					
Z-18	Carton for Belt Cover	147899-0-11				147899-0-11					
B-28	Screw Q'ty	1				2					

INDEX

Parts No.	Ref. No.	Remark	Parts No.	Ref. No.	Remark	Parts No.	Ref. No.	Remark	Parts No.	Ref. No.	Remark
001670-8-14	E-11		013760-8-10	E-7-1		100134-0-01	A-33		102538-0-02	F-14	
009670-5-12	D-9		013761-4-10	B-14		100136-0-01	A-35		102627-0-01	C-4-1	
	F-5			B-30		100260-0-01	B-1		102630-0-01	B-23	
009670-6-12	B-24			B-32			B-6		102631-0-00	B-25	
009670-6-14	A-17			B-47		100265-0-39	B-12		103950-0-02	A-27	
	A-24			B-51			Z-6		104449-0-01	A-2	
009670-8-12	A-5		013770-7-10	B-28		100294-0-01	E-6-3		104450-0-01	A-1	
	D-21			B-36-2		100310-0-01	B-42		104451-0-01	A-9	
	D-43			B-36-4			C-7		104464-0-01	B-29	
	F-20-9			B-52-2		100312-0-01	C-10		104478-0-01	B-48	
009671-0-13	A-11			B-52-4		100327-0-01	C-2		104520-1-00	D-33	
009671-8-13	A-14			D-15		100328-0-01	C-3		104525-0-01	A-34	
009680-6-12	F-16			D-19		100367-0-01	D-24		104546-0-01	F-13	
009680-7-13	A-18			D-40		100398-0-01	A-31		104547-0-01	F-12	
	E-9			D-45		100399-0-01	A-30		104555-0-01	B-21	
	F-21			E-18-1-1		100400-0-00	A-29		104564-0-01	C-12-3	
009680-8-12	Z-18-4		013781-0-12	C-5		100402-0-04	A-25			C-18	
009681-0-12	D-25		015771-0-12	C-12-1		100405-0-01	E-15		104566-0-01	D-7	
009681-2-12	D-16		017762-0-13	E-24-1		100463-0-01	E-24-3		104567-0-01	D-41-3	
009681-6-12	D-41-1-2		021680-2-02	E-18		100471-0-01	Z-9		104619-0-02	E-24-6	
009711-2-12	B-53		025750-1-32	Z-18-3		100477-0-01	Z-14		104689-0-01	B-41	
013680-6-12	A-20		028680-2-42	Z-18-5		100511-0-03	C-19			C-9	
013680-8-12	D-28		045161-0-00	E-22-2		100573-0-01	B-7		104821-0-01	A-3	
	D-34		081002-6-70	B-20		100666-0-02	Z-16		104829-0-01	A-42	
013689-4-12	D-12		081007-0-70	F-19-3			Z-18-2		104830-0-01	A-41	
	D-27-2		081014-6-70	F-11		100887-0-01	Z-8		104832-0-01	A-8	
013760-6-10	B-39		100022-0-04	F-19-9		101487-0-00	B-45		104833-0-01	A-40	
	B-43		100032-0-03	A-38		101572-1-01	Z-4		104847-0-01	D-14	
013760-8-10	B-34-2		100080-0-03	D-4		101706-0-03	B-49-2			D-39	
	B-35-4		100090-0-04	A-44			D-35-2		104848-0-01	D-18	

Parts No.	Ref. No.	Remark	Parts No.	Ref. No.	Remark	Parts No.	Ref. No.	Remark	Parts No.	Ref. No.	Remark
104848-0-01	D-44		118559-0-01	D-42		146329-0-00	F- 8				
104885-0-01	F-19-10		118752-0-01	C-12-2		146330-0-01	B-37				
104897-0-01	C- 8		118761-1-00	D-36		146331-0-01	B-44				
104908-0-01	D- 6		118770-0-01	B-15		146367-0-01	F-19-11				
106120-0-01	Z-10		118837-0-01	Z- 3		147322-0-01	A-37				
106436-0-01	D-30		122771-0-01	A-36-3		147323-0-01	B-13				
106440-0-00	B-35-3		140004-0-01	B-13-3		147326-0-01	B- 5				
106442-0-01	B-35-2		140357-0-01	B-18		147327-1-01	B-46				
107155-0-01	D-32		140407-0-01	E- 4		147328-0-01	E-12				
107428-0-01	B-40-2		140412-0-01	B-16		147333-0-01	D-11				
108520-0-01	A-10		140430-0-01	B-13-10		147334-0-01	D- 1				
108541-0-01	C-12-4		140480-0-01	F-19-4		147335-0-01	D- 5				
108544-0-03	C-13		140503-0-01	E-24-8		147336-0-01	D-31				
108549-0-01	C- 1-1		140518-0-01	F-19-2		147337-0-01	D-24				
108556-0-03	D-41-2		140530-0-01	B-10		147338-0-01	A-19				
108749-0-01	C-16		140553-0-01	B- 8		147339-0-01	A-16				
108801-0-01	D-10		140726-0-00	B-33			A-23				
108802-0-01	D-41-4		141168-0-01	E-22-3		147340-0-01	A-13				
108804-0-01	F- 1		141207-0-01	E- 1		147343-0-01	C- 1-5				
108809-0-01	B-22		141208-0-01	E- 2		147493-0-01	Z-13				
109137-0-01	B-19		141209-0-01	E- 3		147518-0-01	B- 4				
109144-0-01	E- 6-1		142015-0-01	E-16		147557-0-01	A-22				
109145-0-01	E-21		142016-0-01	E-17		147779-0-22	B-12				
109147-0-01	C-11		142017-0-01	E-19			Z- 6				
109150-0-01	C-15		142018-0-01	E-20		147789-0-01	D-26				
109151-1-01	C- 1-2		142403-0-01	C-14		147790-0-01	D-22				
109153-0-01	D-17		142443-0-01	Z- 2		147855-0-01	Z-18-8				
109156-0-01	D- 3		142483-0-01	C- 1-3		147856-0-01	Z-18-7				
109163-0-01	E-13		142708-0-00	B-38		147899-0-11	Z-18				
109171-0-01	D- 8		142746-0-02	C- 1-4		147999-0-01	E- 6-2				
109173-0-01	D-29		142747-0-02	C- 1-6		148296-0-00	B-27				
109195-0-01	A-15		142756-0-01	E-22-1		148297-0-01	D-26				
109405-0-01	F- 2		143196-0-01	F-10		148806-0-01	F- 6				
109714-0-00	Z-11-3		143770-7-10	E-22-1-1		148848-0-01	F-20-5				
110087-0-01	E-24-4		143882-0-01	Z-11-5		148849-0-01	F-20-6				
110340-0-01	E-10		143910-0-01	Z-11-4		149580-0-01	F-19-8				
110367-0-01	B-26		144222-0-01	Z-21		150150-0-01	Z-15				
110436-0-01	Z- 1		144458-0-01	D- 2-2		180018-0-01	A-36				
111456-0-01	A- 6		144564-0-01	D-13		180022-0-01	B-36				
111457-0-01	A- 7		144741-0-01	A-26		180023-0-01	B-52				
111459-0-01	B-31		144869-0-01	F-20-7		180102-0-01	E- 7				
111463-0-01	B- 2		144872-0-01	F-22		180166-0-01	B-11				
111466-0-01	E- 5		144874-0-01	F-20-8		181127-0-01	C- 4				
111469-0-01	E- 8		144875-0-01	F-20-4		181294-0-01	Z-11				
111470-0-00	E-14		144876-0-01	F-20-3		181427-0-01	E-24				
111491-0-01	C- 6		144878-0-01	F-20-1		181476-1-01	F-20				
111863-0-01	B- 3		144943-0-01	D-27		181624-0-01	E-22				
111865-0-01	A- 4		145153-0-01	A-34		181647-0-01	B-35				
112467-0-02	F-20-2		145277-1-03	Z-20		181671-0-01	C-12				
112525-0-00	Z-12		145446-0-01	A-32		181709-0-01	C- 1				
112775-0-01	B- 9		145454-0-01	A-43		181718-0-01	D-41				
112782-0-01	A-12		145465-0-01	B-13-5		181719-0-01	E- 6				
114294-0-01	A-28		145534-0-01	D-38		181936-0-01	D-22-3				
114483-0-01	Z-19		145540-0-01	F-17		181937-0-01	D-22-1				
114561-0-01	A-36-2		145542-0-01	F-15		181938-0-01	D-22-2				
114931-0-01	A-21		145573-0-00	E-23		181941-0-01	D-41-1				
114966-0-01	E-24-7		145737-0-01	F- 4		181994-0-01	B-34				
114967-0-01	E-24-5		145792-0-01	F- 3		181995-0-01	B-49				
116017-0-01	B- 4		145992-0-01	F- 7			D-35				
116794-0-01	D-37		146003-1-01	Z-11-2		182048-0-01	D- 2				
116799-0-01	B-17		146004-0-01	Z-11-1		182049-0-01	B-40				
116953-0-01	C-17		146036-1-01	F-19-12							
117054-0-00	B-50		146037-0-01	F-19-5							
117061-0-01	D-23		146038-0-01	F-19-6							
	Z- 7		146039-0-01	E-24-2							
117117-0-01	B- 5		146040-0-01	F-19-1							
117913-0-00	B-27		146196-0-01	F-23							
117963-0-01	Z-17		146253-0-00	F-18							
118382-0-01	B- 9		146293-0-01	F-19-7							
118558-0-01	D-20		146326-0-01	F- 9							



117-745
195745-2-02
May, 1979
Printed in Japan

From the library of: Superior Sewing Machine & Supply LLC